

438-TG

Toggle Switch Guard

<https://www.gamainc.com/product/438-tg/>

GAMA ELECTRONICS

P.O. Box 1488, Crystal Lake, IL 60039

Phone: 815-356-9600

Fax: 815-356-9603

Email: gama@gamainc.com

www.gamainc.com

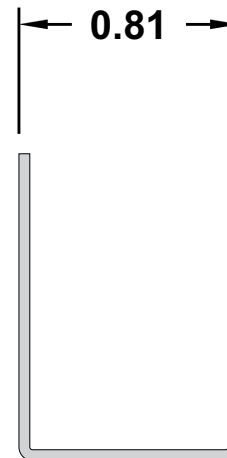
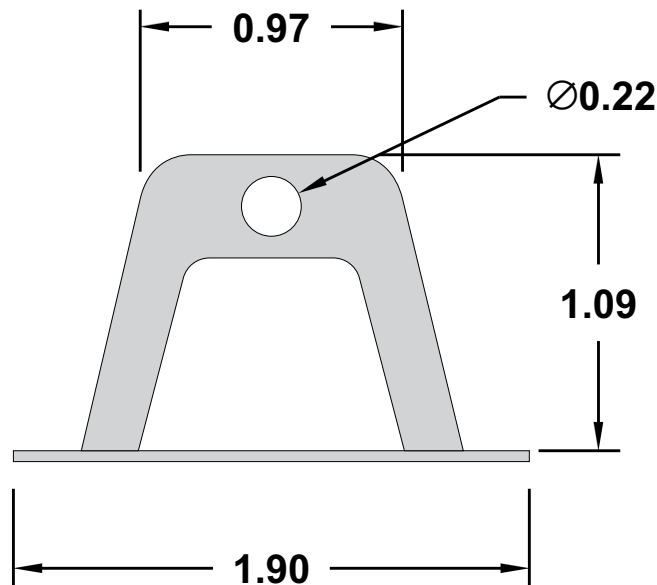
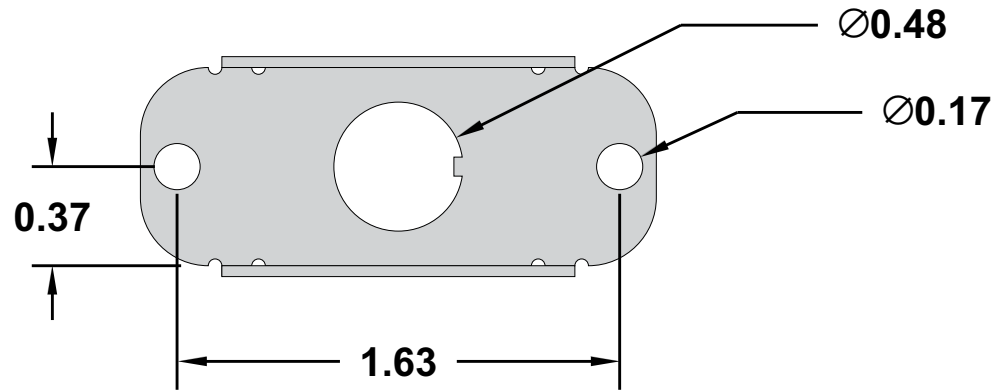

Specifications

- Protects switch from accidental or unwanted operation
- 22 AWG Steel
- (2) Mounting holes for #8 or smaller screw
- Fits all 28 series and 438 series toggle switches

Drawn By: KEG

Information contained herein is proprietary information of GAMA Electronics Inc. The dissemination use or duplication of this information, for any purpose other than that for which the information is provided, is prohibited except by express written permission.

All dimensions are in inches and have a +/- .015" tolerance unless otherwise specified.

Rev: 0

Pg. 1 of 1

Release Date: 12/20/18

Third Angle Projection

