



Included in this Kit:

(1) RFR24V1PR-LS Receiver

(1) 3-Button Transmitter *Image shown with standard transmitter*

Available accessories:

- Additional Transmitter KF340-3

- Waterproof Transmitter KF340-3L-WP

- 6-Pack of Replacement A-23 12V Batteries A23-6

- Long Range Antenna LRA340 **SEE PAGE 3 FOR SETUP**

- Rechargeable Transmitter GKF-WPTX-3L

Overview:

The RF24V1PR-LS is an RF receiver operating at a fixed frequency of 340 MHz. The receiver operates from 24-Volts DC and provides a polarity reversing output. The polarity reversing output incorporates current sensing that will monitor the output current and turn off the output when the operating current exceeds the current setting of the switch. Limit switch inputs are included that will interrupt the output when the limit switch is contacted. The receiver includes two inputs that are used with a manual switch to control the polarity reversing output. The receiver also has a 24-Volt light output.

The transmitter has 3-switches, two for the control of the polarity reversing output and one to activate the light output. The receiver can be configured to operate the output in momentary or latching mode. Up to thirty, three-button transmitters (model KF340-3) can be used to activate the receiver's output. Each transmitter has a unique address that is transmitted when a button is pressed. A "program" button is provided on the receiver to program the transmitter(s) address into the receiver's memory. An LED on the receiver indicates the receiver's programming status and illuminates when either relay is energized.

The receiver includes inputs for manual control of the polarity reversing output. The inputs are labeled "UP Manual" and "Down Manual".

The receiver electronics are encapsulated in a 5" x 5" x 1" mounting tray. The operating range is at least 100 feet.

Maximum Ratings: Power for the receiver can be in the range of 20 to 28VDC. The receiver is reverse polarity protected. The relay contacts are rated at 30 Amps @ 24VDC.

Power Consumption: 10mA when the relays are de-energized, 45mA when the relay is energized.

Input Power Connection: 24VDC power connects to the **+12V** and **GND** terminals.

Output Connection: The output of the receiver is connected to the terminals labeled "To Motor".

Programming Instructions

Each transmitter has its own unique internal address along with the data as to which button is pressed and transmitted. The receiver needs to be programmed to respond only to the specific transmitter it is intended to operate with. The following steps configure the receiver to operate with a particular transmitter. Up to 30 transmitters can be programmed to one receiver. Please read the entire programming procedure before starting. When the receiver enters program mode, all previous transmitter addresses that were programmed will be erased from the receiver's memory.

1. Locate the pushbutton labeled "PROGRAM" on the receiver. Press and hold this button until the red LED next to the program button illuminates (approximately 3 seconds). The receiver is now in the transmitter program mode. Release the button. At this point all previously programmed transmitter addresses are erased from the receiver's memory.
2. To configure the receiver for a latching output, go to Step 4.
3. To configure the receiver for momentary output, press and release the UP button on the transmitter and verify that the red program LED extinguishes and then illuminates (blinks once). Proceed to Step 5.
4. To configure the receiver for latching output, press and release the DOWN button on the transmitter and verify that the red program LED extinguishes and illuminates (blinks once).
5. Repeat previous step for additional transmitters that will operate with this particular receiver. The red LED on the receiver will extinguish and illuminate (blink) once for the first transmitter being programmed, twice for the second, three times for the third, etc. The receiver will not respond to transmitters that have already been programmed. The first transmitter that is programmed determines the receiver's relay operating mode.
6. The receiver will return to normal mode if no transmitter buttons are pressed for 5-seconds. The red LED on the receiver will blink rapidly, then extinguish. The receiver is now in the normal mode of operation. This completes the programming instructions. The receiver will retain all of its programming even when power is removed.

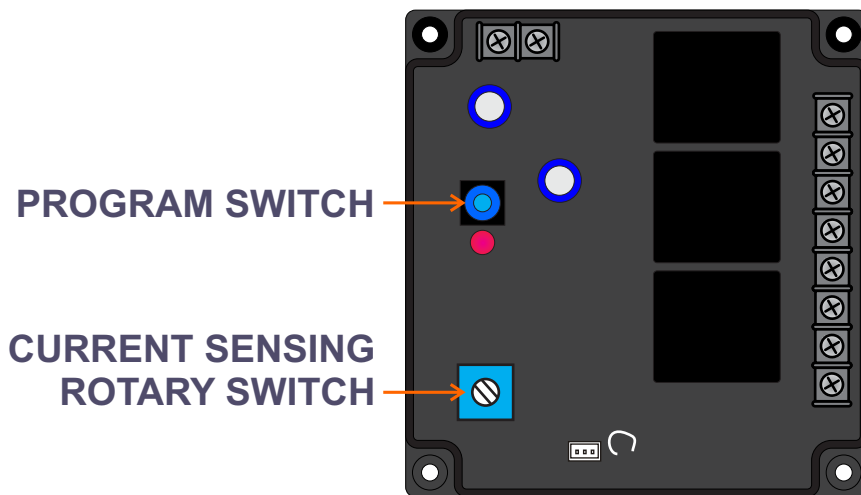

To Add Long Range Functionality

The remote control system is equipped with an internal antenna. The expected range in normal conditions is approximately 100 feet. When additional range is needed, or if the control is placed locations adverse to RF signal reception, a long range antenna can be added to the system. GAMA Electronics long range antenna, part number LRA-340, replaces the internal antenna on the system. In normal operating conditions expected range is greater than 500 feet. If the long range option is purchased with the system, this modification will be made prior to shipment.

NOTE: ONCE THE LONG RANGE MODIFICATIONS HAVE BEEN MADE TO THE SYSTEM THEY CANNOT BE REVERSED.

To add long range functionality:

1. Plug long range antenna (Part number LRA-340) into the long range antenna jack.
2. Clip the Long Range Antenna Bypass Wire (This will deactivate the internal antenna)

NOTE: It is recommended that you cover the exposed wires with RTV silicone sealant.

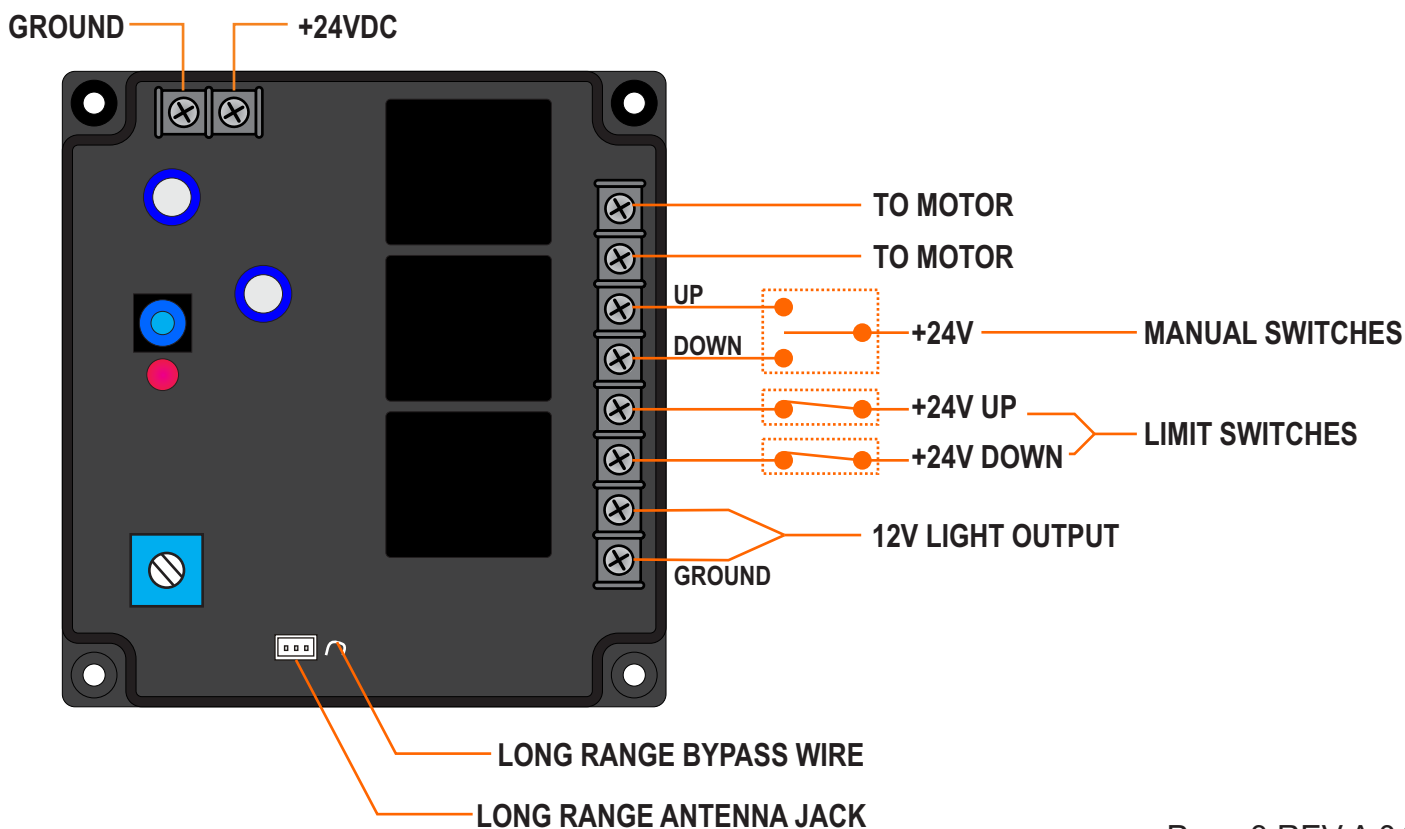

Wiring and Features

Limit Switch Inputs: The receiver has provisions for two normally closed limit switches (not included with the remote control system). The provision on the receiver terminal block are labeled LIMIT UP and LIMIT DOWN. The receiver must see a +24V signal on these lines to operate with the remote control or the manual switch in the UP or DOWN direction.

You will need to connect +24VDC to the common terminal on your limit switches and connect the normally closed terminal on your limit switches to the terminal block positions labeled LIMIT UP and LIMIT DOWN. Wiring your limit switches this way will provide a continuous +24VDC signal to the receiver when the switch is not activated.

When a limit switch is activated the +24VDC connection to the receiver is opened. If the receiver does not see a +24VDC signal on the LIMIT UP or LIMIT DOWN terminal the MOTOR OUTPUT will not function when the UP or DOWN operation is activated on the remote control or the manual switch.

NOTE: IF LIMIT SWITCHES ARE NOT USED FOR ONE OR BOTH DIRECTIONS, YOU MUST SUPPLY A CONSTANT +24VDC SIGNAL TO THE "LIMIT UP" OR "LIMIT DOWN" POSITION ON THE TERMINAL BLOCK FOR THE MOTOR OUTPUT TO FUNCTION.

Manual Switch Inputs: The receiver includes inputs for a manual switch to control the polarity reversing output. The manual control inputs to the receiver are labeled "**Down Manual**" and "**UP Manual**". The manual switch inputs are Normally-Open (NO), and +24 Volts DC is applied to each input to activate the output. A single-pole, double-throw 3-Position momentary-ON, OFF, momentary-ON switch should be used to control the manual switch inputs. Note: The manual switch inputs when activated will take priority over the RF transmitter.

Output Current Sensing: The current sensing circuit will monitor the output current and turn off the output and reset the output for 5-seconds when the output current exceeds the current trip setting of the switch. The output current sensing is adjustable from 5-Amperes to 35-Amperes. There is a 0.5-second delay in the current sensing to allow for motor inrush.

Current Sensing Instructions

Output Current Sensing: The current sensing circuit will monitor the output current and turn off the output and reset the output for 5-seconds when the output current exceeds the current trip setting of the switch. The output current sensing is adjustable from 5-Amperes to 35-Amperes. There is a 0.5-second delay in the current sensing to allow for motor inrush.



The recess down the length of the shaft points to the setting

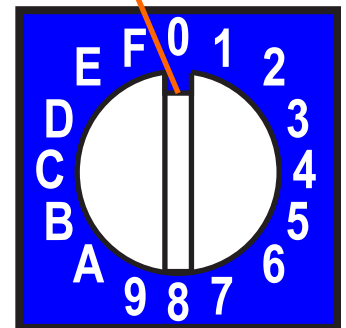

SWITCH SETTING	CURRENT LIMIT
0	5 AMPS
1	7 AMPS
2	9 AMPS
3	11 AMPS
4	13 AMPS
5	15 AMPS
6	17 AMPS
7	19 AMPS
8	21 AMPS
9	23 AMPS
A	25 AMPS
B	27 AMPS
C	29 AMPS
D	31 AMPS
E	33 AMPS
F	35 AMPS

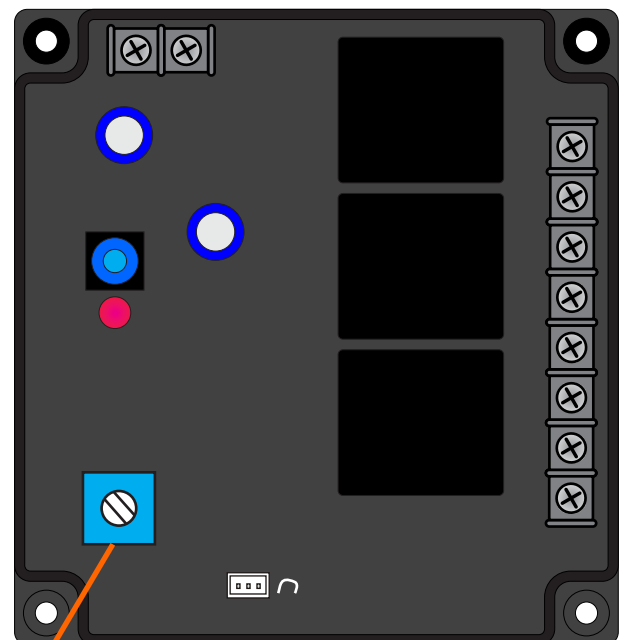

CURRENT SENSING ROTARY SWITCH

Troubleshooting

All remote-control systems shipped by GAMA Electronics are 100% functionally tested just prior to shipment.

If your RF remote control system does not work out of the box, stops working or functions intermittently please take the following steps to resolve common issues. Please note that you must be 2-3 feet away from the receiver when operating the remote control. Operating within 2-3 feet may result in no operation or intermittent operation.

1. Replace the A23 12V Battery in the transmitter

- The remote control can activate during shipping and drain the battery that is installed in the control. We send a replacement battery with the system if this occurs.

2. Check the voltage supply at the receiver

- The receiver is designed to function at 10-15VDC. Voltage on the (+) and (-) terminals on the control should be within this range.

3. Reprogram the remote control

- If the system is non-functional try to reprogram the remote control. The program may not have taken during the programming process or the program button may have been pressed. If the program button is pressed the memory of the remote controls programmed to the receiver are erased.

4. Listen and look for functionality on the receiver.

- The LED that is used for programming the system will illuminate when the receiver is activated. You will also hear a “click” when the internal relays engage. If you can see the LED illuminate and you hear the relay “click” the issue is most likely in the wiring or device being controlled.

5. Check your limit switches

- The system is designed to work with 2 normally closed limit switches. If the control does not see a signal from a limit switch it will not operate. Check the switches and the wires for loose connections or damage.

6. Add a long-range antenna

- If the receiver is in an area that is averse to the reception of an RF signal, such as near a motor or in a metal casing, a long-range antenna may solve the issue. Connect the antenna per the instructions on page 3 and mount the antenna in an exposed area away from any motor.